

# SOUTHWEST IDAHO ELECTRICAL TRAINING CENTER



BLUEPRINT FOR APPRENTICESHIP



# Building Your Future

The Southwestern Idaho Electrical JATC apprenticeship is five-year “earn while you learn” program. Our program is the approved training facility for the International Brotherhood of Electrical Workers (IBEW) Local 291, National Electrical Contractors Association (NECA) and is the largest apprenticeship program federally registered with the Department of Labor in the state of Idaho. Inside Wireman Apprentices perform a variety of skilled tasks.

Some of the major duties for an Inside Wireman include:

- Planning and initiating projects
- Establishing temporary power during construction
- Establishing grounding systems
- Installing electrical service to buildings and other structures
- Establishing power distribution within a project
- Planning and installing raceway systems
- Installing new wiring and repairing old wiring

***Apprentices who are selected for the program do not incur tuition fees associated with traditional colleges or other trade related programs. However, apprentices do have to pay annually for books, transportation, dues, work attire and tools as required by their collective bargaining agreement.***

Applicants who are offered an apprenticeship with our JATC can expect:

- To be placed in job with one of our union electrical contractors
- Be paid for the hours worked
- Receive employer paid benefits: 401k/annuity, family health insurance, personal care account and pension plan
- Have their on-the-job-training hours reported to the state of Idaho
- Attend classes at the JATC at least one evening per week
- Complete homework weekly and take exams at the end of each topic
- Raises upon successful annual completion over the course of five years
- Monthly reporting of work hours to the JATC
- Abide by all JATC policies
- Sign a ten-year indenture agreement
- Make-up any missed class time
- Receive a minimum of 10,000 on-the-job-training hours and 900 related classroom training over the course of five (5) years.
- Advance to a Journey-level electrician upon successful program completion and state testing

## Contact Information

Ed Huskey—Training Director  
[ed@swidjtc.org](mailto:ed@swidjtc.org)

Debbie Draper—Office Manager  
[office@swidjtc.org](mailto:office@swidjtc.org)

Southwest Idaho Electrical Training Center  
(JATC)  
12302 W. Explorer Drive, Suite 130  
Boise, Idaho 83713  
[www.swidjtc.org](http://www.swidjtc.org)

(208) 384-0538

<https://www.facebook.com/Southwestern-Idaho-Electrical-JATC-670295869678912/>

<https://www.linkedin.com/company/swidjtc/>



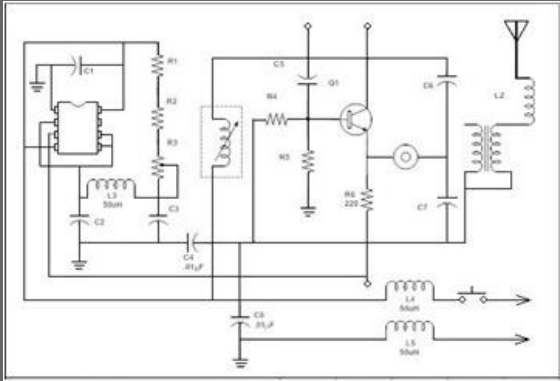

# Starting the Process

## WHAT YOU NEED TO KNOW ABOUT THE APPLICATION PROCESS

The process of selection begins with the apprenticeship application. Applicants can **apply online at a cost of \$ 30.00** (American Express is not accepted). For applicants who would rather pay by check or money order, paper applications can be obtained year round at the JATC office. ***The JATC does not accept cash.***

Applicants have thirty (30) days to complete the application once purchased. This allows enough time to obtain the official documentation needed to qualify the application if an additional math class is not needed (***see minimum requirements in left-hand column.***)

## THE PROCESS IS LENGTHY

The earliest any applicant may be selected is approximately three (3) months. Applicants who meet the minimum requirements will be notified of their aptitude testing date via U.S. mail, within thirty (30) days completing the application. All applicants will be required to complete an online aptitude test consisting of mathematical equations and reading comprehension. This testing is done at the JATC training center and lasts approximately 3 hours. The JATC will notify applicants of their test date and time.

Applicants who pass the aptitude test will move on to the in-person interview with the Joint Apprenticeship Training Committee (JATC). Committee members represent the IBEW and NECA. The interview occurs approximately thirty (30) days after testing. Applicants will receive a letter via U.S. mail notifying them of their interview date and time.

Applicants will be scored by each committee member. All scores are then averaged into a single score and applicants are placed on a ranking list. ***Applicants will stay on the ranking list for two (2) years.*** If not selected prior to two (2) years, the application process will need to be reinitiated.

### APPLICATIONS EXPIRE ONE (1) YEAR FROM THE DATE OF ISSUE

As apprentices are needed, those with the highest ranking score are offered an apprenticeship.

## Minimum Requirements to Apply

- BE 18 YEARS OR OLDER
- HAVE A VALID DRIVERS LICENSE
- HAVE GRADUATED HIGH SCHOOL/G.E.D
- COMPLETED ONE FULL YEAR OF ALGEBRA
- PROVIDE OFFICIAL DOCUMENTATION:
  - OFFICIAL/SEALED H.S. TRANSCRIPTS
  - OFFICIAL G.E.D.
  - PROOF OF ALGEBRA 1 REQUIREMENT
  - COPY OF DRIVERS LICENSE
  - COPY OF DD214 IF SERVED IN MILITARY
- Applicants who are unable to provide proof of the algebra requirement can take our approved online math course for a fee. Once completed, applicants will provide a copy of the certificate issued by the online program to satisfy the requirement.
- The algebra requirement can also be waived if the applicant has 2,000 on-the-job-training hours recorded with the state in the electrical industry
- Non-English diplomas and/or transcripts must be translated and notarized with notary seal

**APPLY NOW**

VISIT: [www.swidjadc.org/applicant](http://www.swidjadc.org/applicant)



## Practice Links

<http://www.electricianapprenticehq.com/aptitude-test-questions/>

<https://www.khanacademy.org/math/algebra>

<http://www.math.com/practice/Algebra.html>

# Aptitude Testing

A sample of the aptitude test can be found on the Electrical Training Alliance (National JATC) website:

<http://electricaltrainingalliance.org/SamplePage>

The following is an example math test question. If you struggle with solving this question, or the additional math questions on the sample test, you will need to re-view similar problems prior to testing.

Consider the following formula:

$$A = B + 3(4 - C)$$

If B equals 5 and C equals 2, what is the value of A?

- A. 7
- B. 11
- C. 12
- D. 17

Consider the following formula:

$$y(x + 5)(x - 2)$$

Which of the following formulas is equivalent to this one?

- A.  $y = 3x^2 + 9x - 30$
- B.  $y = x^2 + 3x - 10$
- C.  $y = 3x^2 + 3x - 10$

The timing of New Year's Day has changed with customs and calendars. The Mayan civilization, on what is now called the Yucatan peninsula of Mexico, celebrated the New year on one of the two days when the noonday sun is directly overhead. In the equatorial regions of the earth, between the Tropics of Cancer and Capricorn, the sun is in this position twice a year, one on its passage southward, and once on its passage northward. At the early Mayan city of Izapa in the southern Yucatan, the overhead date for the sun on its southward passage as August 13. The Mayans celebrated this as the date for the beginning of the New Year. Later at the more northerly Mayan site at Edzna, the corresponding overhead date is July 26. Analyses of Mayan pictorial calendars indication that they celebrated the New Year on August 13 prior to 150 AD, and on July 26 after that year. This change has been explained by archaeological dating showing that 150 AD was the time that the Mayans moved the hub of their civilization from the southern to the northern site. According to the passage, the sun at Edzna was directly overhead at noon on:

- A: July 26 only
- B. August 13 only
- C. July 26 and one other date
- D. August 13 and one other date

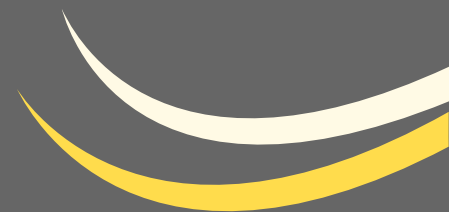

# Does Experience Matter?

Apprentices are entry-level electricians, but many of those selected for the program do have some experience in the industry. There are steps applicants can take to gain experience and/or find out if the electrical trade is one they are well suited for and will enjoy as a lifelong career.

## THE CONSTRUCTION WIREMAN (CW) PROGRAM

The Construction Wireman (CW) program is a *pre-apprenticeship* and one of the more effective means of getting industry experience. Many of the apprentices selected for the program started as construction wiremen. The **CW program differs from the five (5) year apprenticeship in several ways:**

- There are no minimum requirements
- It is not federally registered with the Department of Labor
- CW's do not attend apprentice classes
- There is no fee for the application
- CW's are not placed in jobs
- CW's do not receive the same benefit package as apprentices

## WHY APPLY TO BE A CONSTRUCTION WIREMAN (CW)?

It may seem as though there is no benefit to becoming a CW, but it can be a vital step in landing an apprenticeship. **Here's why:**

- CW's are necessary and needed in the industry
- They perform much of the same work tasks as beginning apprentices
- The JATC helps keep track of hours worked and reports those hours to the state of Idaho
- CW's gain valuable experience on-the-job
- Builds relationships with apprentices, journeymen and contractors
- They earn a wage while applying for the five (5) year apprenticeship
- They receive employer paid health care for themselves after the waiting period
- They can improve their overall interview score
- They can re-interview with the committee once they have worked 500 hours
- They often earn a wage comparable to a 1st year apprentice
- Shows dedication to the goal of acquiring an apprenticeship

## How to Become a CW

- COMPLETE THE CW APPLICATION
- ACTIVELY APPLY FOR CW POSITIONS WITH CONTRACTORS USING THE LIST ISSUED BY THE JATC
- RETURN TO THE JATC IF OFFERED A JOB BY A CONTRACTOR AS A CW
- RECEIVE TRAINING ORDER FROM JATC
- REPORT TO THE LOCAL 291 UNION HALL FOR APPROVAL
- OBTAIN "APPRENTICE LICENSE" AS REQUIRED BY THE STATE OF IDAHO VIA THE DIVISION OF BUILDING AND SAFETY (apprentices and CW's must have this license prior to starting work— Cost \$ 50.00)
- REPORT TO WORK
- REPORT ON-THE-JOB TRAINING HOURS ONLINE TO THE JATC MONTHLY

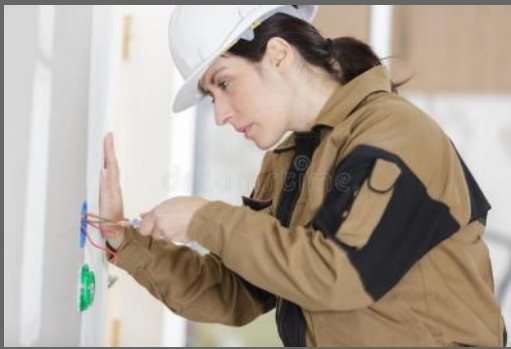

frequently

asked questions

**What if I'm selected for the apprenticeship program and I decide it's not for me?**

Apprentices must sign contracts with the JATC. If an apprentice is "let go" from the program for failure to meet policies or "quits" the program for personal reasons, they will be required to pay back the schooling they have received after their probation period.

## Frequently Asked Questions

### How much does an apprentice make per hour?

Apprentices start at 45% of a journeyman wage. As apprentices complete years of schooling and on-the-job-training hours, they receive wage advancements.

**Sample wages and benefits based on journeyman rate of \$29.46 per hr. as of January 1, 2018 (\*All figures are approximate and subject to change)**

% of Journey-man Rate	Minimum OJT Hours	*Wages	Employer Paid Benefits	*Total
1st Term 45%	0-1000	\$ 13.26 hr	\$ 7.44 hr	\$ 20.70 hr
2nd Term 50%	1001-2000	\$ 14.73 hr	\$ 7.29 hr	\$ 22.22 hr
3rd Term 55%	2001-3500	\$ 16.20 hr	\$ 10.29 hr	\$ 26.49 hr
4th Term 60%	3501-5000	\$ 17.68 hr	\$ 10.58 hr	\$ 28.26 hr
5th Term 70 %	5001-6500	\$ 20.62 hr	\$ 11.18 hr	\$ 31.80 hr
6th Term 80%	6501-8000	\$ 23.57 hr	\$ 11.76 hr	\$ 35.33 hr

### How much does an CW make per hour?

CW's start about the same rate as a 1st term apprentice, without full benefits.

### Why do I have to pay a fee for the apprenticeship program, but not the CW program?

The JATC is a non-profit organization and charged for apprenticeship applicant testing. The CW program does not have applicant testing. Therefore, the cost is not passed onto applicants.

### When does the JATC accept applications?

The JATC accepts applications all year long during business hours

### How do I go about getting a copy of my high school transcripts?

Applicants must contact their high school registrar's office and request an official/sealed copy to be mailed directly to the JATC office.

### What if I took Algebra in college? Can I send a transcript from my college instead of my high school?

Yes and no. You can use your college transcript to fulfill the algebra requirement, but you must also submit your official/sealed high school transcript or G.E.D. proving completion.

### What if my drivers license is from out of state?

Your drivers license does not need to be from Idaho, but it does need to be valid.

### How often does the JATC conduct aptitude testing?

Testing occurs the second Tuesday of each month and starts promptly at 8:30 AM.

### What if I have a testing date and I forget about it or miss it? Can I test the following month?

If you know you will not be available on your testing date, the JATC office can schedule testing for the following month if you contact us in advance. If you are a "no show" for testing, you will need to wait six (6) months to test.

frequently

asked questions

## Frequently Asked Questions

### **What if I don't pass the aptitude test?**

Applicants who do not pass the aptitude test will need to wait six (6) months to retest.

### **Can I work as a CW and apply to the five (5) year program at the same time?**

The JATC encourages applicants to get a job as a CW while applying for apprenticeship. If hired as a CW, applicants can start making money and gain valuable industry knowledge which can help improve interview scores.

### **How soon after I apply to the CW program can I start working?**

That depends on how motivated applicants are to get started in the trade. Because the JATC doesn't find jobs for CW's, the burden is on the applicant to be diligent in trying to get hired.

### **How is the JATC electrical apprenticeship different from college programs?**

College programs charge tuition fees to attend classes and often students must rely on themselves to find a job to get their on-the-job-training hours needed to take the state test to become a journeyman electrician. The JATC doesn't charge tuition for those offered apprenticeship and places their apprentices in jobs so they accrue the hours needed.

### **Can I send someone else to pick up my application for apprenticeship?**

No. All interested applicants must purchase the application in person, with a valid driver's license.

### **Can I bring a copy of my high school transcript to the JATC?**

Yes, IF the transcript is sealed in an envelope from your high school. Transcripts are no longer official if opened by anyone other than the JATC staff.

### **How long are the in-person interviews?**

Interviews are usually about 20 minutes in length.

### **I'm currently in a different electrical apprenticeship program. Can I transfer into this one?**

The JATC does not accept transfers. All applicants must go through the application process. If accepted into the program and you've completed **full** years of schooling with another program and can provide proof of training, you can attempt to test into the next sequential year of training. If you have hours accrued with another program or employer, you will need to have those hours approved by the Division of Building and Safety before they will be accepted by the JATC.

### **I have a felony conviction, can I still apply?**

Yes.

### **After the interview, will I receive my overall score?**

Yes. All applicants who go through the interview process will receive a letter via U.S. mail stating their score. However, applicants will not know where they are on the overall ranking list of applicants during the 2-year period.

### **Does everyone get selected if they apply?**

No. Not every applicant who applies for the program is selected. You can improve your chances by gaining experience as a CW to better your overall score.

### **What if I can't prove I took Algebra 1?**

#### **Can I still apply?**

Applicants can still apply for the program if they take and complete the "approved" math class from the Electrical Training Alliance (National JATC). Here's a link:

[http://  
electricaltrainingalliance.org/  
Learning/OnlineTechMath](http://electricaltrainingalliance.org/Learning/OnlineTechMath)

# Frequently Asked Questions

**If selected for the program, what kind of tools might I need to purchase as a new apprentice?**

**Standard tools include:**

Hacksaw Frame  
Hand Hammer  
Knife  
Pencil  
Pliers (pipe type and side cutters)  
Rule not to exceed 25'  
Screwdriver (ex. Mechanical)

**Journeyman will need:**

Allen wrenches of to 3/8" (folding type)  
Awl  
Crescent Wrench 10"  
Flashlight  
Hacksaw Frame  
Hand Hammer  
Keyhole Saw Handle  
Knife  
Level, small  
National Electrical Code Book (current)  
Offset level (no-dog)  
Padlock  
Pencil  
Pliers (side cutters, diagonals, needle nose and two (2) 10" adjustable)  
Plumb bob  
Rule, not to exceed 25'  
Screwdrivers (ex. "Yankee" style)  
Square (small)  
Voltage Tester  
Tool Box (adequate to carry these tools)  
Tool Pouch  
Wire Strippers (small)  
Gloves

## Other Items You Might Need

In addition to tools, new apprentices and CW's might need to purchase:

- ⇒ Work shirts
- ⇒ Work pants
- ⇒ Work Boots





## Mapping It Out—5 Year Apprenticeship



### TIPS

- ⇒ DO get your documents in order
- ⇒ DON'T leave information off your application
- ⇒ DO take the approved math class if you don't meet the requirement
- ⇒ DO contact the JATC if you move to update address
- ⇒ DO STUDY for your aptitude test
- ⇒ DO PRACTICE your interviewing skills
- ⇒ DO APPLY for the CW program at the same time to help gain experience prior to your interview
- ⇒ DON'T quit your current job unless an apprenticeship has been offered to you
- ⇒ DON'T get discouraged. It's a long process
- ⇒ DO ask questions! We are happy to help!

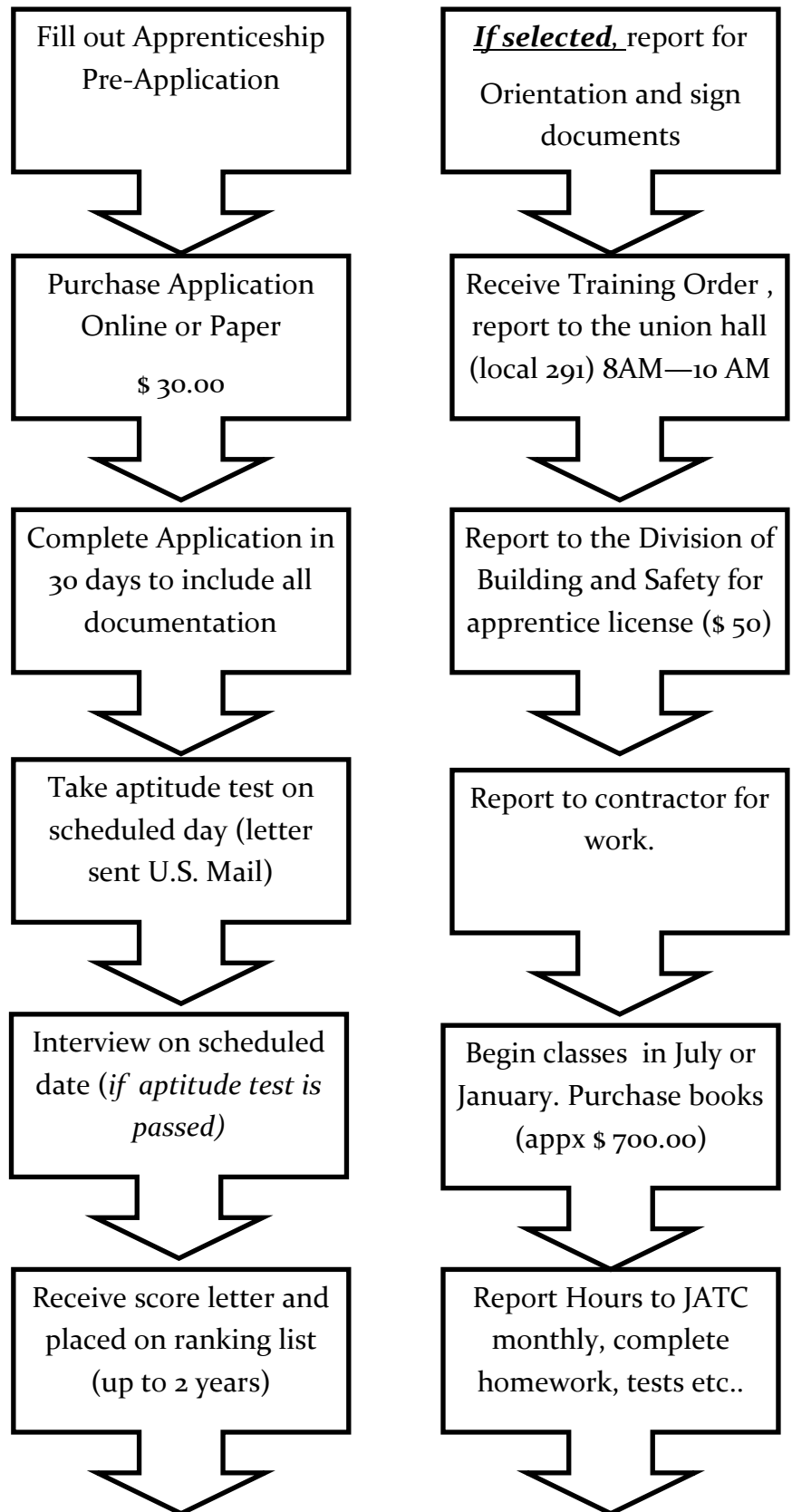

## Mapping It Out—CW Pre-Apprenticeship



### TIPS

- ⇒ DO apply for the CW program if applying for the 5-year apprenticeship program
- ⇒ DO visit the contractors in person if able
- ⇒ DO contact all the larger contractors to better your odds of getting hired
- ⇒ DO ask questions! We are happy to help!

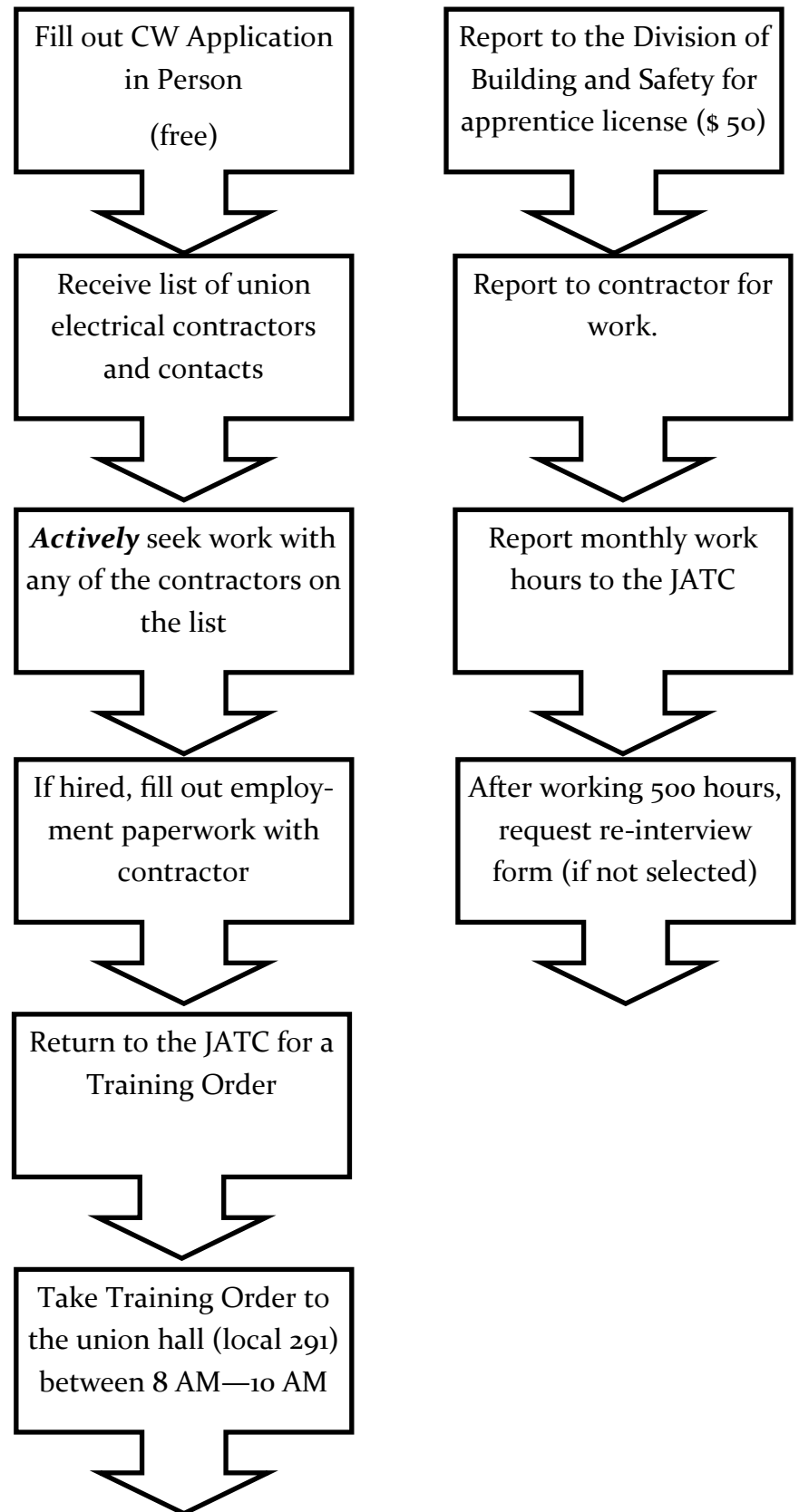



## APPRENTICE APPLICANT APPEALS PROCESS

If you feel you have been unjustly treated with regards to selection for our apprenticeship program, you may appeal the committee's decision.

Any appeal must be filed in writing within 30 days of the date of notification to the applicant regarding the JATC's decision concerning application for apprenticeship.

Please send appeals in writing to:

**IBEW Local 291**  
**225 N. 16th St. Suite 110**  
**Boise, Idaho 83702-5187**

## A Note To Those With Disabilities

We recognize and comply with our obligation under the Americans with Disabilities Act to not discriminate against qualified persons with disabilities.

If you are a persons with a physical or mental impairment (including learning disabilities) that you believe may affect your ability to complete any aspect of the application process (including testing) and if you need an accommodation to ensure that the test battery accurately measures your skills and abilities, **please notify the JATC, as soon as possible, and not later than upon receipt of notification that you are scheduled to take the NJATC test battery.** Accommodations requests given on the test day cannot be addressed on that day. In most cases you will need to provide:

1. Documentation of your disability
2. Documentation of the need for a particular accommodation.

Your request will be considered promptly.

## Affirmative Action

The recruitment, selection, employment and training of apprentices during their apprenticeship, shall be without discrimination because of race, color, religion, national origin, sex or age—with the exception that applicants must be at least 18 years old to apply and at the time of indenture. The JATC does not, and will not, discriminate against a qualified individual with a disability because of the disability of such individual.

The sponsor will take affirmative action to provide equal opportunity in apprenticeship and will operate the apprenticeship program as required under applicable law and lawful regulations issued thereunder.

Applicants who meet all basic requirements will be interviewed by the JATC. Apprentices will be selected in order of their final ranking.

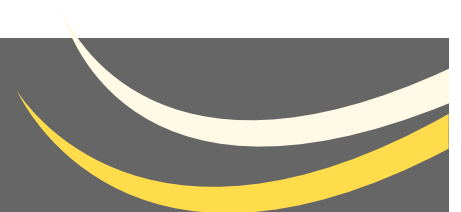

## The *Mission* of the Southwest Idaho

**Educate the members of the International Brotherhood of Electrical Workers and the National Electrical Contractors Association; ensuring and providing the Electrical Construction Industry with the most highly trained and highly skilled workforce possible.**